



KONICA MINOLTA

KONICA MINOLTA PHOTO IMAGING, INC.
©2004 Konica Minolta Photo Imaging, Inc.
under the Berne Convention
and the Universal Copyright Convention.

Printed in Malaysia
9222-2181-19 MY-A409



KONICA MINOLTA

DYNAX 7D MAXXUM 7D

- E** POCKET REFERENCE GUIDE
- F** GUIDE DE RÉFÉRENCE DE POCHE
- S** GUÍA DE REFERENCIA DE BOLSILLO



Important Note

For Windows 98/98SE:

- The Windows 98/98SE driver software supplied with the product must be installed before initially connecting the camera to the computer.

All later Windows versions and Mac OS:

- No special driver is required to access the camera from the computer.



Note importante

Avec Windows 98/98SE :

- Le pilote Windows 98/98SE fourni avec l'appareil doit être installé avant de connecter l'appareil au micro-ordinateur.

Toutes autres versions Windows et Mac OS :

- Aucun pilote n'est nécessaire pour accéder à l'appareil depuis le micro-ordinateur.



Nota importante

Para Windows 98 / 98SE:

- El software controlador de Windows 98 / 98SE proporcionado con el producto se debe instalar antes de conectar por primera vez la cámara al ordenador.

Todas las versiones posteriores de Windows y de Mac OS:

- No requieren un controlador especial para acceder a la cámara desde el ordenador.

**NAMES OF PARTS
NOMENCLATURE
NOMBRES DE LAS PARTES**

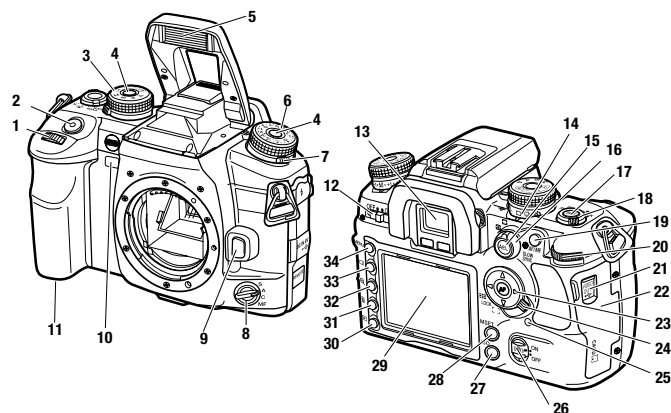

1. Front control dial
2. Shutter-release button
3. Exposure-mode dial
4. Dial release
5. Flash
6. Exposure-compensation dial
7. Flash-compensation dial
8. Focus-mode dial
9. Lens release
10. Self-timer lamp
11. Battery-chamber door
12. Main switch
13. Viewfinder*
14. Drive mode dial
15. AE lock button
16. Metering-mode dial
17. White-balance button
18. White-balance dial
19. AF/MF button

20. Rear control dial
 21. USB port/Video-out terminal
 22. Card-slot door
 23. Controller & Spot-AF button
 24. Focus-area switch
 25. Access lamp
 26. Anti-Shake switch
 27. Camera-sensitivity (ISO) button
 28. Memory set button
 29. LCD monitor*
 30. Playback button
 31. Delete button
 32. Magnification button
 33. Display button
 34. Menu button
- * Do not touch

1. Molette de sélection avant
2. Déclencheur
3. Sélecteur de mode d'exposition
4. Touche du sélecteur (verrou)
5. Flash
6. Sélecteur de correction d'exposition
7. Sélecteur de correction d'expo au flash
8. Sélecteur de mode de mise au point
9. Déverrouillage de l'objectif
10. Lampe témoin du retardateur
11. Porte du logement batterie
12. Interrupteur principal
13. Viseur*
14. Sélecteur de mode d'entraînement
15. Touche de mémorisation d'expo. (AEL)
16. Sélecteur de mode de mesure
17. Touche de balance des blancs
18. Sélecteur de balance des blancs
19. Touche AF/MF
20. Molette de sélection arrière
21. Connecteur USB/sortie vidéo
22. Porte du logement carte mémoire
23. Touche centrale du contrôleur/AF spot
24. Curseur de sélection de zone AF
25. Lampe témoin d'accès
26. Commutateur d'Anti-Vibration
27. Touche de sensibilité (ISO)
28. Touche de réglage mémoire
29. Écran ACL*
30. Touche Lecture
31. Touche d'effacement
32. Touche d'agrandissement
33. Touche d'affichage
34. Touche Menu

* Ne pas toucher

1. Sintonizador de control delantero
 2. Disparador
 3. Sintonizador modo de exposición
 4. Disparador del sintonizador
 5. Flash
 6. Sintonizador compens. exposición
 7. Sintonizador compensación flash
 8. Sintonizador modo de enfoque
 9. Enganche del objetivo
 10. Luz del temporizador automático
 11. Puerta del compartimento de pilas
 12. Interruptor principal
 13. Visor *
 14. Sintonizador modo funcionamiento
 15. Botón bloqueo AE
 16. Sintonizador modo medición
 17. Botón del balance de blancos
 18. Sintonizador balance de blancos
 19. Botón de AF/MF
 20. Sintonizador de control trasero
 21. Puerto USB / Terminal salida vídeo
 22. Puerta de la ranura para tarjetas
 23. Controlador y Botón de AF Puntual
 24. Cambio del área de enfoque
 25. Luz de acceso
 26. Interruptor de Anti-Vibración
 27. Botón sensibilidad cámara (ISO)
 28. Botón de establecer memoria
 29. Monitor LCD *
 30. Botón de reproducción
 31. Botón de eliminar
 32. Botón de ampliación
 33. Botón de visualización
 34. Botón del menú
- * No tocar

(Continued on the next page./Suite page suivante./Continúa en la página siguiente)

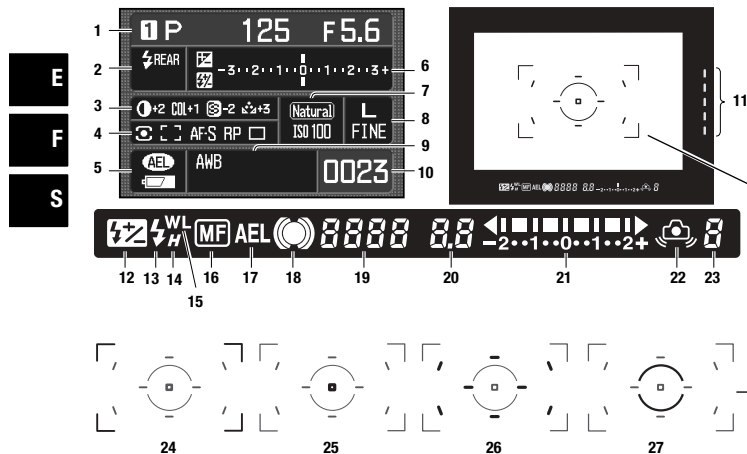

- | | |
|--|--|
| 1. Afficheur de mémoire/
mode d'exposition/Exposition | 13. Témoin de flash |
| 2. Afficheur de flash | 14. Indicateur de synchro
haute-vitesse |
| 3. Afficheur d'effets numériques | 15. Indicateur de flash sans
cordon/flash détaché |
| 4. Afficheur de mesure/zone AF/
mode AF /priorité déclenchement/
mode d'entraînement | 16. Indicateur de mise au point
manuelle |
| 5. Afficheur de mémo d'expo./d'état
de la batterie | 17. Indicateur de mémorisation
d'expo |
| 6. Échelle IL | 18. Témoin de mise au point |
| 7. Afficheur de mode couleur/
sensibilité | 19. Vitesse d'obturation |
| 8. Afficheur de définition/
qualité d'image | 20. Ouverture |
| 9. Afficheur de balance des blancs | 21. Échelle IL |
| 10. Compteur de vues | 22. Signal de bougé de l'appareil |
| 11. Échelle d'Anti-Vibration | 23. Compteur de vues restantes |
| 12. Indicateur de correction d'expo
flash | 24. Zone AF large |
| | 25. Zone AF spot |
| | 26. Zones AF ponctuelles |
| | 27. Zone de mesure spot |

- | | |
|---|------------------------------|
| 1. Memory/exposure mode/
exposure panel | 16. Manual focus indicator |
| 2. Flash panel | 17. AE lock indicator |
| 3. Digital Effects panel | 18. Focus signal |
| 4. Metering/AF area/AF mode /
Release priority/Drive mode
panel | 19. Shutter-speed display |
| 5. AE lock/battery condition
panel | 20. Aperture display |
| 6. EV scale | 21. Ev scale |
| 7. Color mode/camera-sensitivi-
ty panel | 22. Camera-shake warning |
| 8. Image size / quality panel | 23. Frames-remaining counter |
| 9. White-balance panel | 24. Wide focus frame |
| 10. Frame counter | 25. Spot AF area |
| 11. Anti-shake scale | 26. Local Focus areas |
| 12. Flash-compensation indicator | 27. Spot-metering area |
| 13. Flash signal | |
| 14. High-speed sync. indicator | |
| 15. Wireless/Remote flash indica-
tor | |

- | | |
|--|--|
| 1. Modo memoria / exposición /
panel de exposición | 15. Indicador flash inalámbrico/
remoto |
| 2. Panel del flash | 16. Indicador de enfoque manual |
| 3. Panel de Efectos Digitales | 17. Indicador de bloqueo del AE |
| 4. Panel de Medición/Área AF/
Modo AF/Prioridad/
Modo funcionamiento | 18. Señal de enfoque |
| 5. Panel de bloqueo AE / estado pila | 19. Visor de la velocidad
de obturador |
| 6. Escala de Ev. | 20. Visor de la apertura |
| 7. Panel del modo color/sensibilidad | 21. Escala de Ev. |
| 8. Panel de tamaño / calidad imagen | 22. Advertencia de cámara movida |
| 9. Panel del balance de blancos | 23. Contador de fotos que faltan |
| 10. Contador de fotogramas | 24. Marco de enfoque amplio |
| 11. Escala de la Anti-Vibración | 25. Área de AF puntual |
| 12. Indicador compensación de flash | 26. Áreas de enfoque locales |
| 13. Señal del flash | 27. Área de medición puntual |
| 14. Indicador de sincronización de
alta velocidad | |

TABLE OF CONTENTS

E

QUICK STARTA-1	Camera-sensitivity (ISO)A-12
Full-auto program default settings/ Focus signal/Flash signal/ Camera-shake warningA-2	White balanceA-13
How to operate the menuA-3	Preset/CustomA-13
Monitor displayA-4	Color temperatureA-14
RECORDINGA-5	MemoryA-14
BasicA-5	Settings stored/ Store memoryA-14
Lens notes/Flash range/ Flash modes/Slow sync./Image size & quality/ Instant playback periodA-5	Recall memoryA-15
ExposureA-6	Recording mode resetA-15
Combination in PASM modes/ Program shift/ Exposure warning/ Metering in M mode.....A-6	PLAYBACKA-16
Manual shift/Exposure & flash com- pensationA-7	Basic playbackA-16
MeteringA-8	Enlarged playback.....A-16
Exposure lock (AEL)	Deleting single images/ Delete/Lock/ Index playback or file browser/ View folder/Format/ Slide showA-17
Focus modesA-8	CUSTOMA-18
MF mode.....A-8	Custom menuA-18
Focus area switch/ AF/MF buttonA-9	SETUPA-20
Drive modesA-10	Setup menuA-20
Self-timer/BracketingA-10	Reset defaultA-22
Interval.....A-11	DATA TRANSFERA-24
Color modesA-12	PictBridgeA-24
Digital FXA-12	Connecting to computerA-25
	Download imagesA-26
	Disconnecting from computerA-27
	TROUBLESHOOTINGA-28

FOCUS (p. 52-54)

MF mode (p. 52)

Instruction manual page reference

QUICK START

(p. 19, 21, 22, 24, 27, 28)

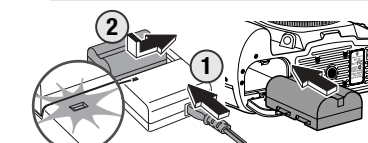

1. Attach a lens, and charge the battery. Load the battery into the camera.
 - Charging time is approx. 150 minutes.

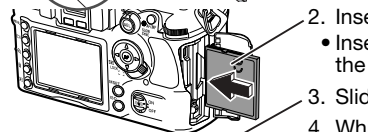

2. Insert a memory card.
 - Insert the card so the face is toward the front of camera.

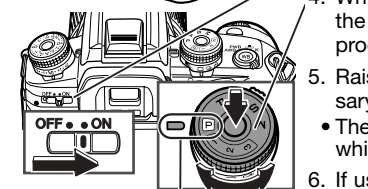

3. Slide the main switch on.
4. While pressing the dial release, set the exposure-mode dial to full-auto program.

Full-auto program

5. Raise the flash if necessary.
 - The flash always fires while up.



6. If using a zoom lens, rotate the zoom ring to frame the subject.

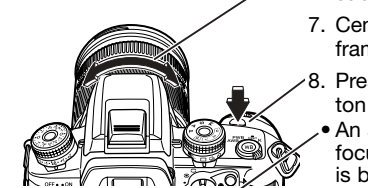

7. Center the subject in the wide focus frame.

8. Press the shutter-release button partway down.
 - An audio signal confirms focus and the AF area used is briefly illuminated.

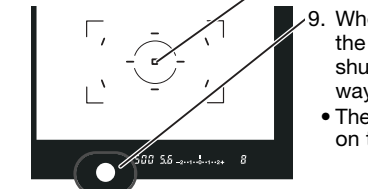

9. When focus signal appears in the viewfinder, press the shutter-release button all the way down to take a picture.
 - The recorded image is played back on the monitor for 2 seconds.



Full-auto program default settings (p. 40)

E

The following settings are reset automatically when the exposure-mode dial is turned to full-auto program:

Flash mode	Fill flash or Red-eye reduction*
Metering mode	14-segment honeycomb-pattern
Focus mode	Automatic AF(A)
AF area	Wide focus area
Drive mode	Single-frame advance
Exposure compensation	0.0Ev
Flash compensation	0.0Ev
Flash control	ADI
White Balance	Auto
ISO	100
Image size	L: 3008x2000
Image quality	Fine
Color mode	Natural: sRGB
Digital FX	0
Bracket setup	0.3Ev/3 frames
Noise reduction	On

* Whichever of the two flash modes was last set.

Focus signal (p. 29)

● Single AF - focus is confirmed and locked.

⦿ Continuous AF - focus is confirmed.

⦿ Continuous AF - focusing. Shutter is locked.

⦿ (Blinks) Cannot focus - shutter is locked.

Flash signal (p. 31)

⚡ Flash is charged and ready.
⚡ (Blinks after exposure) Flash exposure was sufficient.

Camera-shake warning (p. 30)

📷 Image may be blurred because of camera shake. Use the flash or a tripod.

HOW TO OPERATE THE MENU

(p. 64, 82, 92, 102)

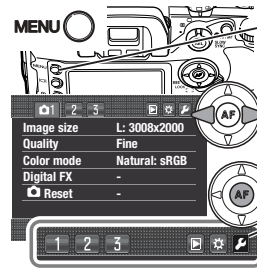

1. Press the menu button to open the menu.

2. Use the left/right keys to select the menu section.

- To change between menus, highlight the menu tab and press the central button to open the menu.

📷:Recording ▶: Playback
⚙️:Custom ⚙️: Setup

3. Use the up/down keys to select the item to be changed.

4. Use the right key to display the options.

5. Use the up/down keys to highlight the option and press the central button to select it.

- If "Enter" is displayed, press the central button to open the setting screen.

6. To close the menu, press the menu button.

The following notation is used for menu guidance. The example below refers to the description above. "MENU" indicates pressing menu button, ">" indicates the next operation or position, and "•:enter" for pressing the central button of the controller. The list of options in parentheses show the default in bold.

MENU > 1 > Audio signals > Select option* > •:enter > MENU (* On, Off)

MONITOR DISPLAY

(p. 33, 34, 35, 37)

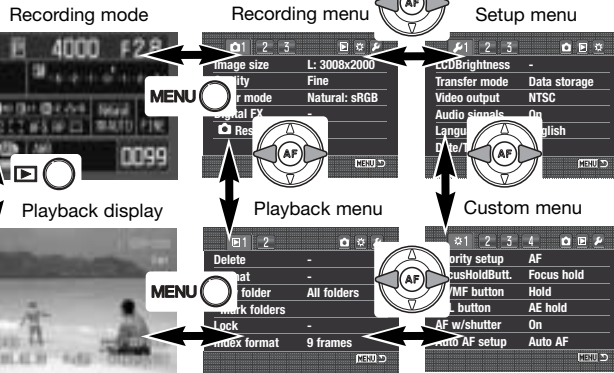

Full recording display Basic recording display Recording display off

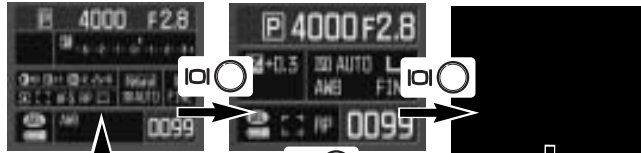

Full playback display Image only

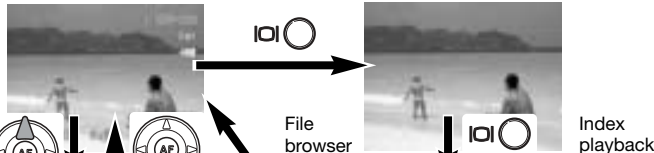

Playback histogram

A-4 Quick Start

BASIC

Lens notes

All Konica Minolta AF lenses and Minolta AF lenses are compatible. Because the camera uses an APS-size CCD, multiply the focal length of the lens by 1.5 to calculate the approximate equivalent focal length in 35mm. For example, a 17-35mm lens will have a similar angle of view as a 25-52mm lens on a 35mm camera.

Flash range of built-in flash at ISO100 (p. 31)

f/2.8:1.0 ~ 4.3m (3.3 ~ 14.1 ft.), f/5.6:1.0 ~ 2.1m (3.3 ~ 6.9 ft.)

Changing the flash mode (p. 71)

MENU > > Flash mode > Select option* > •:enter > MENU
(*Fill-flash, Red-eye reduction, Rear sync, Wireless)

Slow-shutter sync (p. 47)

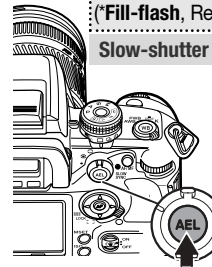

Available in full-auto program, P and A exposure modes. Used to balance the ambient and flash exposures.

1. Raise the built-in flash or turn the accessory flash on.
2. While pressing the AE lock button, press the shutter-release button all the way down to take the picture.

Changing image size (p. 66)

MENU > > Image size > Select option* > •:enter > MENU
(*L:3008x2000, M: 2256x1496, S: 1504x1000)

Changing image quality (p. 66)

MENU > > Quality > Select option* > •:enter > MENU
(*RAW, RAW&JPEG, Extra fine, Fine, Standard)

Changing the instant playback period (p. 77)

MENU > > Inst.Playback > Select period* > •:enter > MENU
(*10 sec., 5 sec., 2 sec., off)

RECORDING

Recording A-5

EXPOSURE

-  Full-auto program
- (1-3) Memory registers
- (P) Program
- (A) Aperture priority
- (S) Shutter priority
- (M) Manual exposure

Combination in P/A/S/M modes (p. 40, 42-44)

Mode	Aperture	Shutter	Flash sync.
P	Automatic	Automatic	1/125s or slower. 1/160s or slower when Anti-Shake is off.
A	by control dials	Automatic	
S	Automatic	by control dials	
M	by rear control dial	by front control dial	

Faster shutter speed can be used with high-speed sync with the Program flash 5600HS(D) or 3600HS(D).

Program shift (PA/PS) (p. 41)

In P mode, the control dials shift the aperture/shutter speed combination. The front dial shifts the shutter speed and the rear dial the aperture.

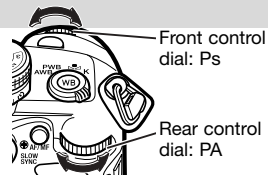

Exposure warning (p. 40, 42-44)

 If either or both the aperture and shutter-speed displays blink, the exposure is beyond the exposure control range of the camera and lens. Adjust the exposure until the blinking stops.

Metering in M mode (p. 44)

The Ev scale displays the Ev difference between the set exposure and the metered exposure. The increments on the scale depend on the exposure-compensation dial position. The examples below are based on a 0.5 Ev increment.

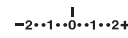
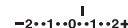
-  The set and metered exposures are equal.
-  0.5Ev more than the metered exposure.

(Continued on the next page.)

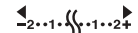
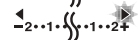
-  0.5Ev more than the scale limit
-  1Ev or more than the scale limit

Manual shift (p. 44)

In the manual exposure mode, press and hold the AEL button and turn either control dial to shift the aperture and shutter-speed combination without affecting the total exposure.

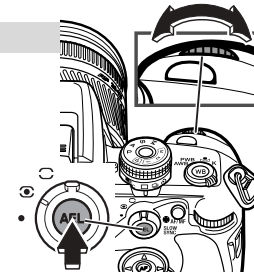

Exposure and flash compensation (p. 48)

Exposure compensation

To manually adjust the metered exposure +/- 3Evs in 1/2Ev or +/- 2Evs in 1/3 Ev increments.

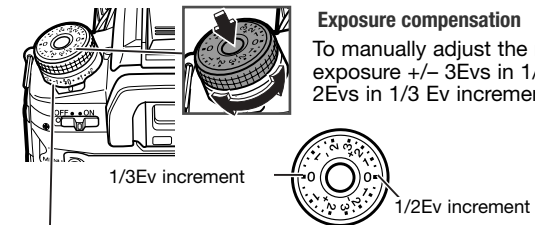

Flash compensation

To manually adjust the output of the built-in or an attached accessory flash up to +/- 2 Ev in 1/2 Ev increments.

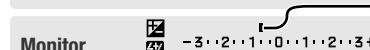

Compensation display

Viewfinder	Exposure compensation value (Example: -0.7Ev)
	
Monitor	Flash compensation value (Example: +1.5Ev)
	

METERING

(p. 46, 50)

E

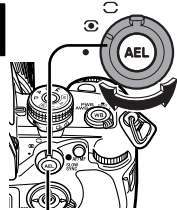

- ☉ **14-Segment Honeycomb-Pattern Metering:** for most photographic situation.
- **Spot Metering:** uses the spot-metering area in the viewfinder to metering specific portions of the scene.
- ☉ **Center-weighted Metering:** measures the entire image area with emphasis given the central region.

Exposure lock (AEL) (p. 46)

The AEL button locks a metered exposure without locking the focus.

1. With the area to be metered framed, press and hold the AEL button (1).
2. Frame the subject (2).
3. Press the shutter-release button partway down to focus (3) and then all the way down to take the picture.

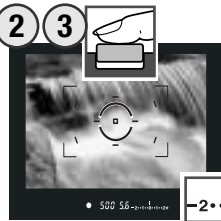

Locked exposure
Difference between the metered and locked exposure.

FOCUS

(p. 52-54)

Turn the dial to the appropriate position: A: Automatic AF (for most situations), C: Continuous AF (for moving subjects), S: Single-shot AF (for stationary subjects), or MF: Manual focus.

MF mode (p. 52)

1. Turn the focus-mode dial to MF.
2. Turn the focusing ring until the subject appears sharp.

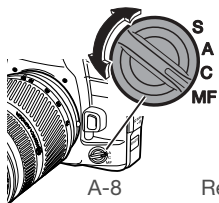

A-8

Recording

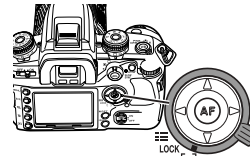

Focus-area switch (p. 54)

The AF area can be specified.

Spot and Wide AF

1. Turn the focus-area switch to wide.
2. Press the controller's eight-way keys to focus using the wide focus area.
Press the central button of the controller to use the spot AF area.
3. While pressing the controller, press the shutter-release button to take the picture.

Spot and local focus areas

1. Turn the focus-area switch to focus-area selection.
2. Press the controller's eight-way keys to select one of the eight local focus areas. Press the central controller button to select the center spot AF area. The camera focuses when the controller is pressed.
3. While pressing the controller, press the shutter-release button to take the picture.

Focus area lock

1. Select the focus area.
2. Turn the focus-area switch to the lock position to fix the area.

AF/MF button (p. 53)

The AF/MF button switches between autofocus and manual focus without changing the focus-mode dial.

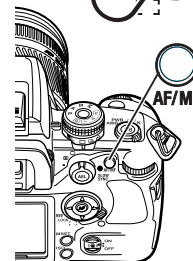

Recording

A-9

DRIVE MODES

(p. 56-58)

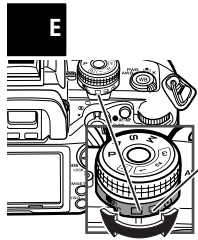

Single-frame advance, continuous advance, bracketing (both single-frame and continuous advance), and a 10 sec. and 2 sec. self-timer can be selected by rotating the drive-mode dial.

Self-timer (p. 57)

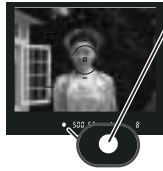

- Place the camera on a tripod, then turn the drive-mode dial to the 10s or 2s self-timer position.
- Center the subject in the focus frame, and press the shutter-release button partway down to confirm the focus.
- Press the shutter-release button all the way down to start the timer.
 - Turn the camera off or select another drive mode to cancel 10-second self-timer countdown. The 2 second self-timer countdown cannot be canceled.



Bracketing (p. 58)

- Turn the drive-mode dial to single-frame advance (S) or continuous advance (C) bracketing.
 - When the flash is raised, a flash bracket is made.

- Set the bracketing increment and number of frames for the bracket on the menu.

exposure bracket

flash bracket

MENU > 2 > setup or setup > Select option* > •:enter
 (*0.3Ev/3frames, 0.3Ev/5frames, 0.5Ev/3frames, 0.5Ev/5frames)

(Continued on the next page.)

- Select the bracket order.

2 > Bracket order > Select option* > •:enter > MENU
 (*0 → - → +, → or → - → 0 → +)

- The Ev scale displays the number of frames and bracketing increment.

(Example)

Exposure bracketing: 0.3Ev/5frames
 Flash bracketing: 0.5Ev/3frames

- Press the shutter-release button to start bracketing.
 - The corresponding index disappears as the images are taken.

Interval (p. 78)

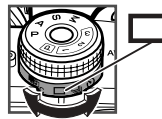

- Turn the drive-mode dial to the single-frame advance position.
- Setup the interval parameters.

MENU > 3 > Interval > Setup > •:enter

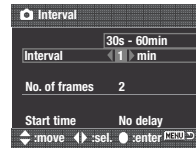

- Use the up/down keys to select the parameter to be set among the interval period, number of frames, and start time.
- Use the left/right keys to set the parameter.

- Press the central button to complete the operation.
- To start the interval series, execute the following:

MENU > 3 > Interval > Start > •:enter > MENU

- Confirm focus and press the shutter-release button to start the interval recording.

COLOR MODES (p. 68)

E MENU > 1 > Color mode > Select option* > > MENU

***(Natural: sRGB...**natural color reproduction for most purposes.
Natural+:sRGB...increased contrast.
 Embed Adobe RGB...similar to Natural Color, but uses the extended gamut of the Adobe RGB color space and is embedded in the image file.)

DIGITAL FX (p. 69)

MENU > 1 > Digital FX > Enter > > select the parameter with the up/down keys > change the parameter with left/right keys > > MENU

Contrast :	Decrease	- ... 0 ... +	Increase
Saturation :	Subdues colors	- ... 0 ... +	Accentuates colors
Sharpness :	Softens details	- ... 0 ... +	Accentuates details
Hue :	Shifts color space	- ... 0 ... +	Shifts color space

CAMERA-SENSIVITY(ISO) SETTING (p. 51)

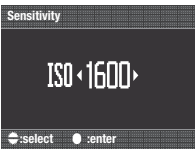

Seven settings can be selected for camera sensitivity (ISO); Auto, 100, 200, 400, 800, 1600, and 3200. 3200 is activated with "ISO menu set" in custom section 4).

- The higher the ISO setting, the higher the sensitivity and the longer the flash range, but noise is increased at the same time.

1. Press the camera-sensitivity (ISO) button.
2. Use the control dials or left/right keys to change the ISO.
3. Press the central button to set the ISO.
 - Zone matching can be activated in "ISO button set" in custom section 4. Zone matching improves reproduction of high-key or low-key scenes.

WHITE BALANCE (p. 60-62)

Auto white balance is used when the white-balance dial is set to AWB. Other dial positions give different controls.

- Auto white balance: for automatic setting. Preset white balance: to set the white balance to a specific light. Custom white-balance: to calibrate the camera to a specific lighting condition. Color temperature: to set the white balance to a specific color temperature.

Selecting preset white balance (p. 60)

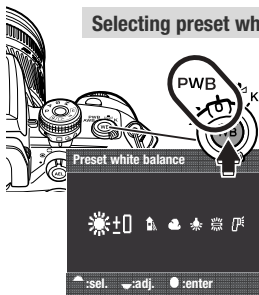

1. Turn the white-balance dial to the preset white balance position, and press the white-balance button.
2. Turn the front control dial to select the preset white balance and turn the rear control dial to adjust the selected preset white balance.
3. Press the central button to complete the operation.

Custom white-balance calibration (p. 61)

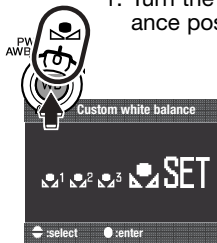

1. Turn the white-balance dial to the custom white balance position, and press the white-balance button.
2. Use the control dials to select "Set", and press the central button.
3. Place a white object in the spot-metering area and press the shutter-release button to calibrate in camera.
4. Use the control dials or left/right keys to select the white-balance register, 1, 2 or 3.
5. Press the central button to complete the operation.

(Continued on the next page.)
 Recording A-13

Color temperature setting (p. 62)

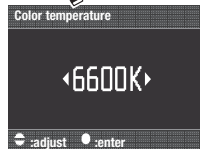

1. Turn the white-balance dial to the color temperature position, and press the white-balance button.
2. Use the control dials to set the color temperature.
 - The front dial adjust the temperature in thousands and the rear in hundreds.
3. Press the central button to complete the operation.

MEMORY

(p. 63)

The memory function allows you to store the current camera setting and recall them.

Settings stored:

- Exposure mode (P, A, S, M)
- Shutter speed in S/M
- Aperture in A/M
- Focus mode (A, C, S, Manual)
- Focus area (Wide, Local)
- Bracket setup
- Exposure compensation value
- Flash compensation value
- Drive mode
- Flash mode
- AF/Release priority
- Digital FX
- Metering mode
- Flash-metering mode
- Auto AF setup
- Color mode
- ISO setting
- Image size
- Image quality
- White balance

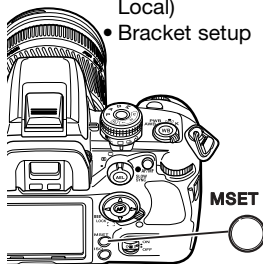

Store memory

1. Confirm the settings to be saved on the camera.
 - Memory screen shows the settings to be saved.
2. Press the memory set button.

(Continued on the next page.)

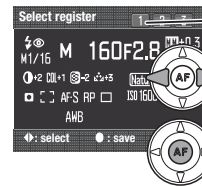

3. Use the left/right keys to select the memory register, 1, 2, or 3.
4. Press the central button to save the settings.
 - All setting in the selected register are replaced with the new settings.

Recall memory

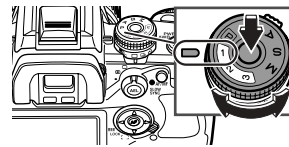

While pressing the dial release, turn the exposure-mode dial to the appropriate memory register, 1, 2, or 3.

- The settings are displayed on the monitor.

RESET (RECORDING MODE RESET)

(p. 70)

MENU > 1 > Reset > Enter > enter > MENU

Recording settings are reset as follows.

Focus area selection:	Spot AF area
Preset-white balance:	Daylight: 0
Custom white balance:	Register 1
Color temperature:	5500K
Digital FX:	0
Flash mode:	Fill flash or Red-eye reduction*
Flash control:	ADI
Manual flash:	1/1
setup:	0.3Ev/3 frames
setup:	0.3Ev/3 frames
Exp. compensation by control dial:	0.0

* Whichever of the two flash modes was last set.

BASIC PLAYBACK (p. 34-36, 38, 84-88)

 Press the playback button.

To search images

To rotate images

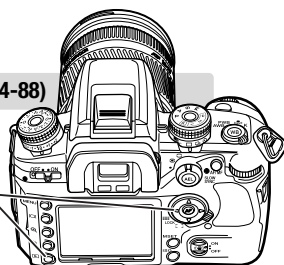

Enlarged playback (p. 38)

- Images can be viewed with enlarged playback except RAW files.

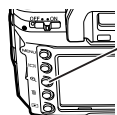

1. With the image to be enlarged displayed, press the magnification button.
 - The image is shown at maximum magnification.



2. Turn the front control dial to display other images, and the rear control dial to change the magnification.
 - Press the four-way key of the controller to scroll the enlarged image.

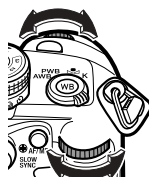

3. Press the central button to display the entire image with the area magnified indicated by a frame.
 - Turn the front control dial to display other images, and the rear control dial to change the size of the magnification area.
 - Press the four-way key of controller to scroll the magnification area.
 - Press the central button to enlarge the magnification area.
 - Exit enlarged playback by pressing the magnification button.

Magnification area

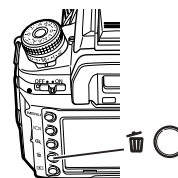
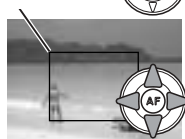

Deleting single images (p. 36)

1. With the image to be deleted displayed, press the delete button.
2. Use the left/right keys of the controller to highlight "Yes.", and press the central button to execute the command on the confirmation screen.

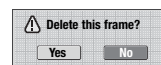

Delete (p. 84): erases single or multiple images.

MENU >  1 > Delete > Select option* > •:enter > MENU
(*Marked frames, All in folder, All on card)

Lock (p. 86): prevents images from being deleted.

MENU >  1 > Lock > Select option* > •:enter > MENU
(*Marked frames, All in folder, All on card, Unlock folder, Unlock card)

Index playback or File browser (p. 87): selects the index format.

MENU >  1 > Index format > Select option* > •:enter > MENU
(*16 frames, 9 frames, 4 frames, File browser)

View folder (p. 85): selects the folder to be viewed.

MENU >  1 > View folder > Single folder > •:enter > Folder name > Select folder > •:enter > MENU

- "Folder name" option is below the "View folder" option.
- The "All in folder" option in the delete and lock functions refer to the folder specified here.

Format (p. 85): initializes the card. Locked images are deleted.

MENU >  2 > Format > Enter > •:enter > MENU

Slide show (p. 88): display images automatically. Select the folder with the view-folder option.

MENU >  2 > Slide show > Enter > •:enter > MENU

CUSTOM MENU

(p. 94-101)

E

Camera can be customized. Default settings are in bold.

⚙️ 1

- Priority setup
 - **AF** (shutter releases when focus is confirmed.)
 - Release (shutter releases regardless focus.)
- FocusHoldButton
 - **Focus Hold** (Press the lens' focus hold button to lock focus.)
 - D.O.F preview (Press the lens' focus hold button to stop down the aperture.)
- AF/MF button
 - **Hold** (Press and hold the button to switch between AF and MF.)
 - Toggle (Press the button and release to switch between AF and MF. Press again to return to the original focus mode.)
- AEL button
 - **AE hold** (Press and hold to lock exposure.)
 - AE toggle (Press once to lock, press again to unlock.)
 - Spot AE hold (Press and hold to lock exposure.)
 - Spot AE toggle (Press once to lock, press again to unlock.)
- AF w/shutter
 - **On** (AF activated with shutter-release button.)
 - Off (AF not activated with shutter-release button.)
- Auto AF setup
 - **Auto AF** (Automatically switch between continuous and single-shot AF.)
 - DMF (Direct Manual Focus.)

⚙️ 2

- Ctrl dial set
 - **SS** **F/No.** (Control dial setup)
 - **F/No.** **SS** (Control dial setup)
- Exp.Comp.
 - **Off**
 - Front dial (For exposure compensation)
 - Rear dial (For exposure compensation)
- Ctrl dial lock
 - On (Control dials are functional only when shutter speed and aperture are displayed.)
 - **Off** (Control dials are always functional.)
- Exp.comp.set
- AF illuminator
 - **Ambient & flash** / Ambient only
 - **On** / Off

⚙️ 3

- Shutter lock
 - **On** (Shutter is locked when no lens is mounted.)
 - Off (Shutter can be release without lens mounted.)
- AF area setup
- Monitor Disp.
 - **0.3s. display** /0.6s. display / Display off
 - **Automatic** (Monitor off when using viewfinder.)
 - Manual (Monitor is always on.)
- Rec. display
 - **Auto rotate** (Images are oriented for viewing.)
 - Horizontal (Image are not rotated.)
- AS finder disp.
 - **On** (Anti-shake scale visible)
 - Off (Anti-shake scale off)

⚙️ 4

- ISO button set
 - **ISO** (Camera sensitivity can be changed.)
 - Zone Matching (To use Zone Matching with high and low-key scenes.)
- ISO menu set
 - **100-1600** /100-3200
- M set button
 - **Memory** (To save camera settings.)
 - Menu shortcut (To jump to a specified menu section.)
- Custom reset
 - Enter (To reset the custom menu.)

⚙️ CUSTOM

SETUP MENU

(p. 104-112)

E

Default settings are in bold.

1

- LCD Brightness Enter > adjust with left/right keys.
- Transfer mode
- **Data storage** (To transfer data to a computer)
 - PTP (For PictBridge compatible printers)
 - NTSC / PAL (The default differs with region.)
 - **On** / Off
- Video output Japanese / **English** / German / French / Spanish / Chinese / Italian / Swedish
- Audio signals
- Language
- Date/Time set Enter > Select with left/right keys > Adjust with up/down keys > •:enter > MENU

2

- File # memory
- On / **Off** (Memorizes the file number of the last image saved.)
- Folder name
- **Std. form** (Numerical: 100KM023)
 - Date form (By date: 100YMMDD)
- Select folder Select folder > •:enter > MENU (To select existing folders.)
- New folder Enter > •:enter > MENU (To create new folders.)

3

- LCD backlight
- 1 minute/30 seconds/10 seconds/**5 seconds** (To specify the monitor illumination period.)
- Power save
- 30 minutes/10 minutes/5 minutes/**3 minutes**/1 minute (To specify the auto-power-save period.)
- MenuSec.Memory
- **Off**/On (To activate menu section memory.)
- Delete conf. "Yes"/"**No**" (To specify which button is highlighted when a confirmation screen opens.)
- Clean CCD Enter > •:enter > Yes > •:enter > detach the lens > clean CCD (see instruction manual) > attach lens > turn off the camera. (To allow the CCD to be cleaned.)
- Reset default Enter > •:enter > Yes > MENU. (To reset the camera to its initial settings (see page A-22).

SETUP

RESET DEFAULT

(p. 112)



E

The reset-default function resets the following settings:

Recording mode

Recording display	Full display
Focus area selection	Spot AF area
Preset white balance	Daylight 0
Custom white balance	Custom white balance 1 (Daylight)
Color temperature	5500K
Camera sensitivity (ISO)	100
Memory	Canceled

Recording menu



Image size	L: 3008 x 2000
Image quality	Fine
Color mode	Natural: sRGB
Digital FX	0
Flash mode	Fill flash
Flash control	ADI
Manual flash	1/1
 setup	0.3Ev/3 frames
 setup	0.3Ev/3 frames
Bracket order	0 > - > +
Instant playback	2 seconds, Image & Info.
Noise reduction	On
Interval set	1 minute, 2 frames, no delay

Playback mode

Playback display	Single-frame playback
View folder	All folders
Index format	9 frames
Date imprint	Off

A-22 Setup

Custom menu

Priority setup	AF
Focus Hold Button	Focus hold
AF/MF button	Hold
AEL button	AE hold
AF with shutter	On
Auto AF setup	Auto AF
Control dial set	 SS  F/No.
 Exposure Comp.	Off
Control dial lock	Off
Exposure Comp. set	Ambient & flash
AF illuminator	On
Shutter lock	On
AF area setup	0.3s display
Monitor display	Automatic
Recording display	Auto rotate
AS finder display	On
ISO button set	ISO
Zone matching	High key
ISO menu set	100-1600
Memory set button	Memory

Setup menu

LCD Brightness	Reset
Transfer mode	Data storage
Audio signals	On
File # memory	Off
Folder name	Standard form
LCD backlight	5 seconds
Power save	3 minutes
Menu Sec. Memory	Off
Delete confirmation	"No"

Setup A-23

SETUP

PICTBRIDGE

(p. 132)

E

Images from the camera can be printed directly from a PictBridge compatible printer.

- Neither RAW nor Adobe RGB-embedded images can be printed in PictBridge.

1. Turn on the printer.
2. Insert the card to the camera and turn on the camera.
3. Set the transfer mode to PTP.

MENU > 1 > Transfer mode > PTP > •enter > MENU

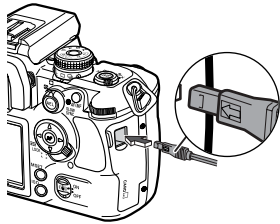

4. Slide open the USB/Video out terminal cover, and connect the camera and printer with the USB cable.

- Insert the smaller plug with its arrow facing the camera back.

Total number of prints Number of copies

5. Use the left/right keys to display the image to be printed.
6. Use the up/down keys to select the number of copies to be printed.
7. Repeat the previous steps for all images to be printed, and press the central button.
8. Confirm the setup and press the central button to start printing.

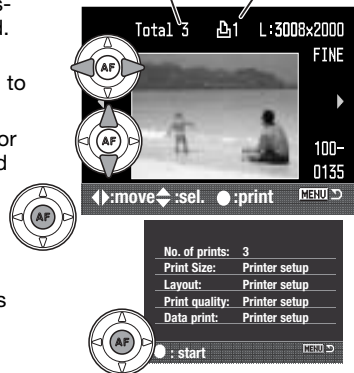

A-24 Data Transfer

CONNECTING TO COMPUTER

(p. 121)

These instructions explain how to connect the camera to the computer with Windows XP/2000/Me or Mac OS X/9.

Refer to the camera's instruction manual on how to install the Windows 98/98SE driver as well as connecting and disconnecting to a computer using Windows 98.

When the camera's memory card is full, transfer the data to a computer. The data can then be deleted from the card so more images can be recorded.

1. Set the transfer mode to data storage, and turn off the camera.

MENU > 1 > Transfer mode > Data storage > •enter > MENU

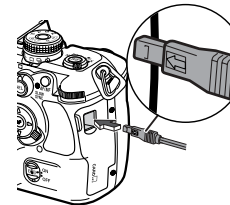

2. Start up the computer.
3. Connect the camera and computer with the USB cable.
4. Turn on the camera.

5. When the camera is properly connected to the computer, a drive icon, or volume, appears in My Computer or on the Desktop.



Double click on "My computer".

Windows 2000:



Windows XP:



Data Transfer

A-25

TRANSFER

Download images from the camera to the computer

E

Windows

1. Right click on the “Start” button
-> “Explore.”
 - The screenshots can vary depending on the operating system.
2. When the My-computer window is opened, a “removable disk” icon is displayed.
3. Double click on the icon to access the camera’s memory card.
 - The DCIM folder is displayed.
4. Simply drag and drop the folder from the card to a location on the computer’s hard drive.

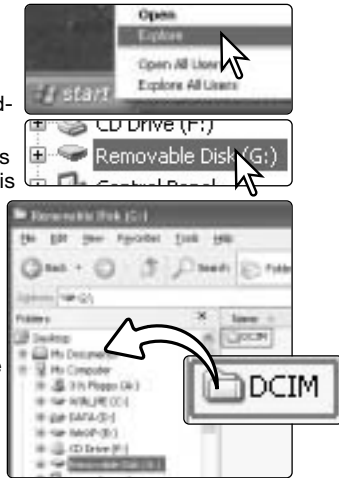

Mac OS

1. A removable disk icon appears on the desktop after connecting the camera to the computer.
2. On Mac OS X, the iPhoto Application may open.
3. Drag and drop the DCIM folder to your hard drive.

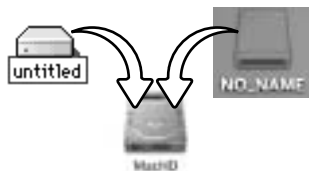

Disconnecting from computer (p. 128)

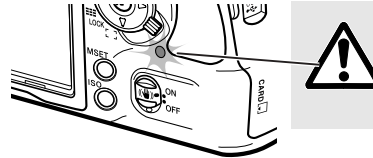

Never disconnect the camera when the access lamp is lit - the data or memory card may permanently be damaged.

Windows

1. Click once on the unplug-or-eject-hardware icon located on the task bar.
2. Click on the small window to stop the device.
3. The safe-to-remove-hardware window opens. Click OK.



4. Turn the camera off. Disconnect the USB cable.

Mac OS

1. Confirm that the access lamp is not lit.
2. Drag the mass-storage device icon and drop it into the trash.
3. Turn the camera off, and then disconnect the USB cable.

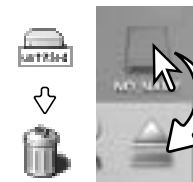

TRANSFER

Use DiMAGE Viewer to edit your images. Install DiMAGE Viewer from the DiMAGE Viewer CD-ROM.

TRUBLESHOOTING

E

Problem	Cause	Solution
Nothing displayed on monitor.	The monitor is turned off.	Press the display button to turn the monitor on.
	The LCD backlight is off or power save is active.	Press any button to activate the camera. The length of the LCD backlight and auto-power-save period can be changed.
	The battery is dead.	Recharge the battery.
	The AC Adapter is not connected properly.	Check the adapter is connected to the camera and a live electrical outlet.
	This camera does not display a live image on the monitor.	Use the viewfinder to compose the picture.
“Err” is displayed on monitor and camera doesn’t work.	The camera is hot or it has been left in a very hot environment.	Turn off the camera and allow it to cool. If “Err” is still displayed after it cools, remove and replace the battery or power cord.
The recorded images were greenish or yellowish.	Auto white balance could not compensate for a special lighting condition.	Use the preset or custom white balance.

Problem	Cause	Solution
“0000” is displayed and shutter will not release.	Card is full.	Insert a new memory card, delete some images, or change the image-quality and/or image size setting.
Shutter will not release.	Cannot focus because the subject is too close.	The subject must be within the focus range of the lens.
Pictures are not sharp.	A special situation is preventing the autofocus system from focusing.	Use the focus-lock function to focus on an object at the same distances as the subject or use manual focus.
	Pictures were taken in low-light situations without flash.	Use Anti-shake or a tripod, change the camera sensitivity to a higher setting, or use the flash.
Inaccurate exposures. The arrows on each side of the Ev scale blink.	The scene is outside the metering range.	In dark conditions, use the camera flash. Under bright light, use a neutral density filter on the lens.
Unable to play back a recorded image.	The wrong folder is selected.	Select the proper folder where the images are stored.
The color of image differs when viewing it on the computer.	The computer monitor is not calibrated properly.	Set the monitor’s color temperature to 6500K and the gamma to 2.2.